

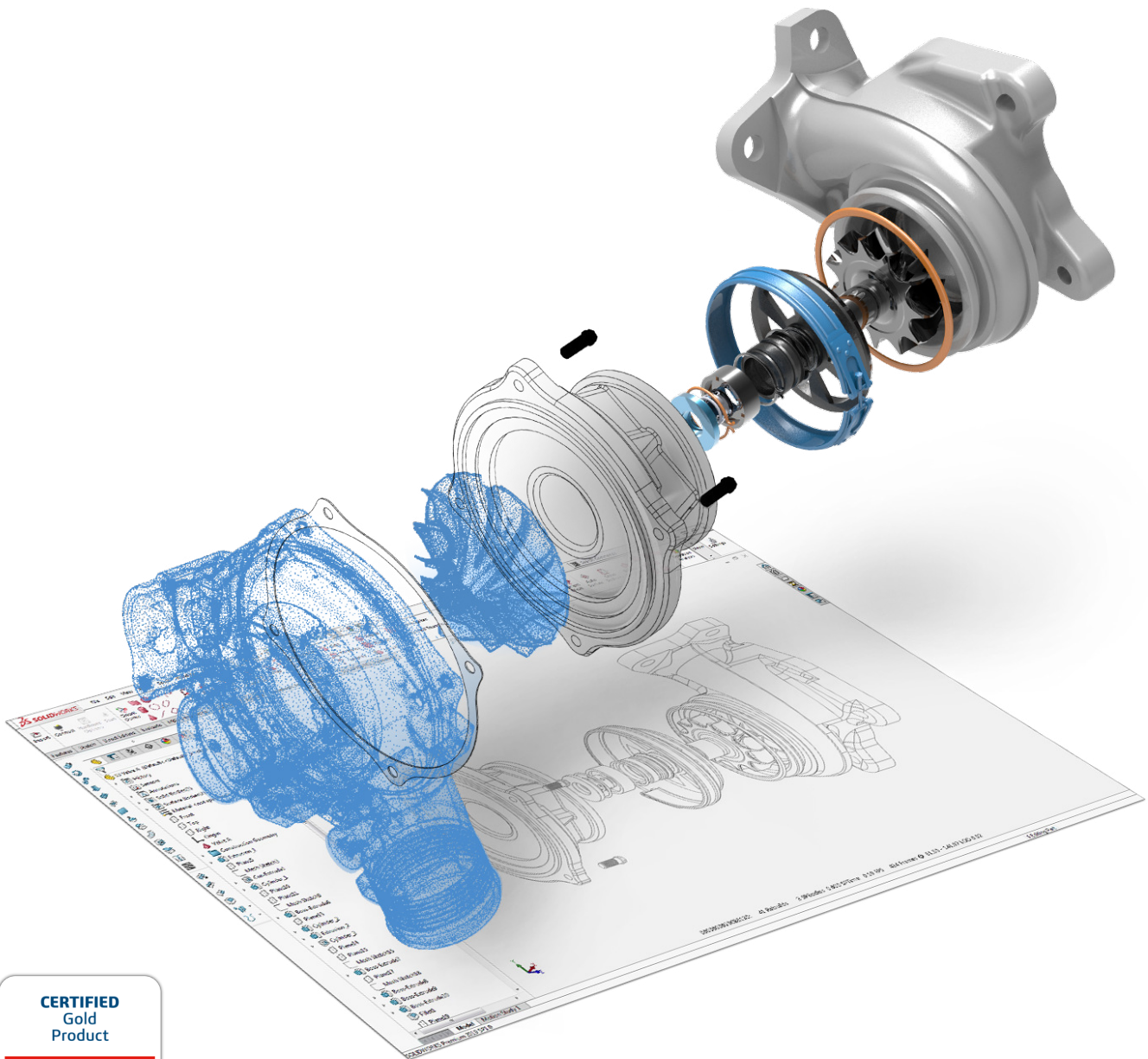

Geomagic for SOLIDWORKS

The Only Complete Scan-to-SOLIDWORKS Solution



CERTIFIED
Gold
Product



OQTON



Geomagic for SOLIDWORKS

Imagine being able to capture anything in the physical world and have a digital solid model of it in minutes.

Geomagic® for SOLIDWORKS® is the industry's most complete integrated Scan-to-SOLIDWORKS model solution. Reduce the time required to build complex 3D models of real world objects by directly scanning or importing scan data into SOLIDWORKS. The advanced, automated wizards quickly and easily create accurate sketches, surfaces or feature-based editable solid parts inside SOLIDWORKS.

Geomagic for SOLIDWORKS is a software toolset that plugs directly into your SOLIDWORKS environment giving you advanced capabilities to make tools point clouds and polygons more usable in your design process. This software supports a range of 3D scanners as well as the import of standard point and polygon file formats including color point data. You can import data or scan directly in SOLIDWORKS and use the feature extraction wizards to extract CAD sketches, surfaces and solids.

Effortless Design At Your Fingertips

Use proven industry-leading tools from Geomagic directly inside your SOLIDWORKS environment. Easily create solid, feature-based parts using the precise scan registration, automated smoothing, mesh editing, auto sketch creation and intelligent extraction of feature tools implemented inside SOLIDWORKS. Make use of deviation analysis tools along-side your modeling process to confidently create CAD bodies that are accurate to your input scan data.

Rapidly Recover Lost Design Data

Lost design data? Have an old part with no drawings? Have worn or broken molds that need to be recreated? Bring legacy parts into a digital design environment and combine scan-driven modeling with dimension driven processes. Geomagic for SOLIDWORKS lets you quickly and easily create SOLIDWORKS parts for highly complex and broken parts in one seamless scan-based design workflow.

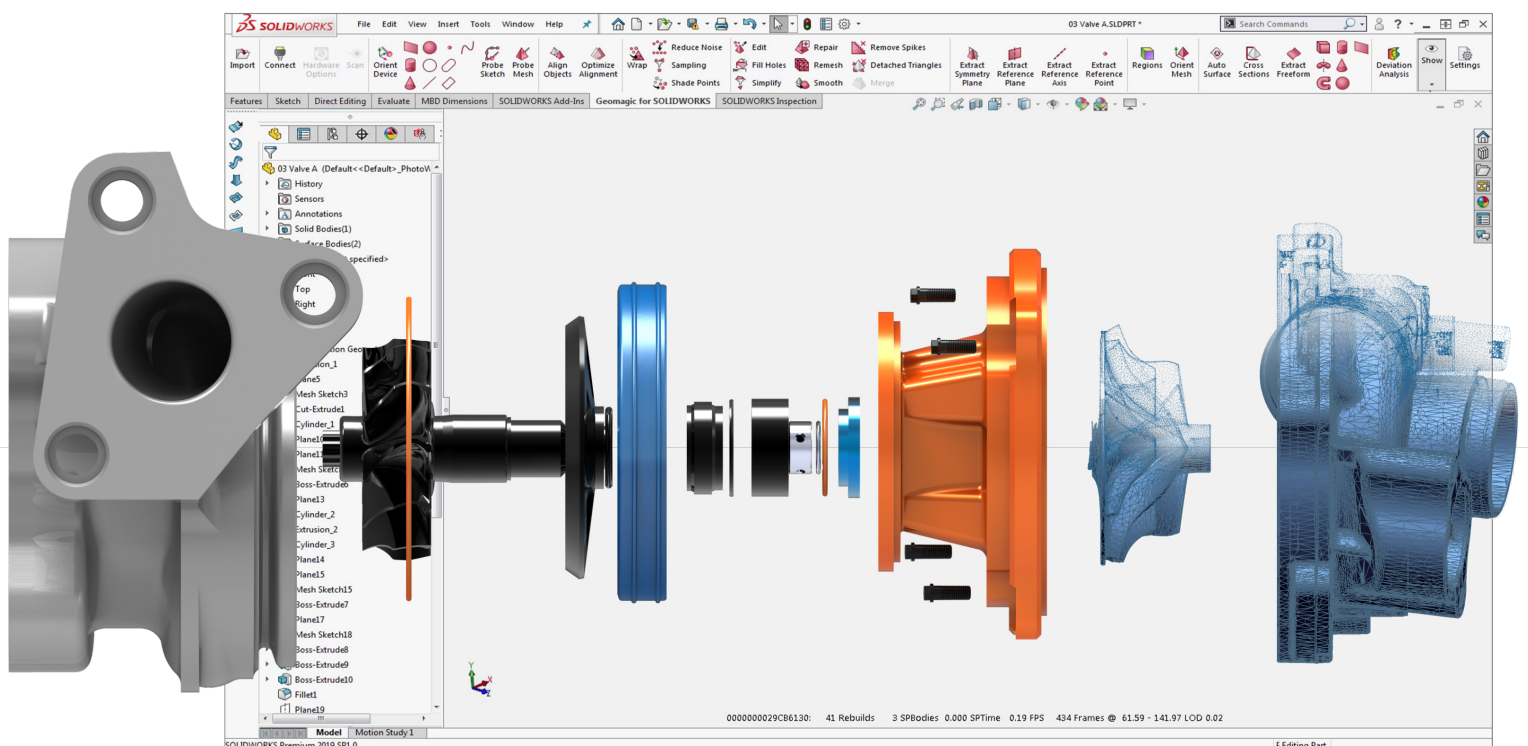

Open Up A World Of Possibilities With Geomagic For SOLIDWORKS

Geomagic for SOLIDWORKS is a bridge between physical parts and your CAD environment enabling rapid design, engineering, and production. Improve upon, learn from, customize and reuse designs that surround you every day. Bring physical objects into SOLIDWORKS and design around existing parts for perfect fits.

Do The Impossible

Create products that cannot be designed without reverse engineering. Build components that integrate perfectly with existing products or customized parts that require a perfect fit with the human body. Use proven industry-leading tools from Geomagic to make organic shapes useful in your SOLIDWORKS environment. Capture the design intent of complex geometry that cannot be measured with traditional hand tools or measuring equipment.

3D Comparison with Deviation Analysis

Quickly and easily compare a CAD object and a mesh object. Every wizard in Geomagic for SOLIDWORKS has a deviation analysis tool to check feature accuracy as you model. Get real-time information on your features to help make design decisions and maintain design intent.

Powerful and Flexible

Create solid parts with Geomagic for SOLIDWORKS. The combination of mesh editing and point cloud processing, automatic and guided feature extraction and accurate and fast exact surface fitting to organic 3D scans help create useful featurebased solid models. Now, you can scan virtually anything and create manufacturing-ready designs.

Scanning Freedom

Geomagic for SOLIDWORKS supports a range of industrial 3D scanners for direct Scan-to-SOLIDWORKS. Truly integrated 3D scanning and probing capability allow for non-contact measurement of complex or delicate shapes, as well as the contact measurement of geometric features. Directly capture and process color 3D scans inside SOLIDWORKS with 3D scanning devices that support capture of color information. Additionally you have the ability to import color per vertex or texture mapped scans.

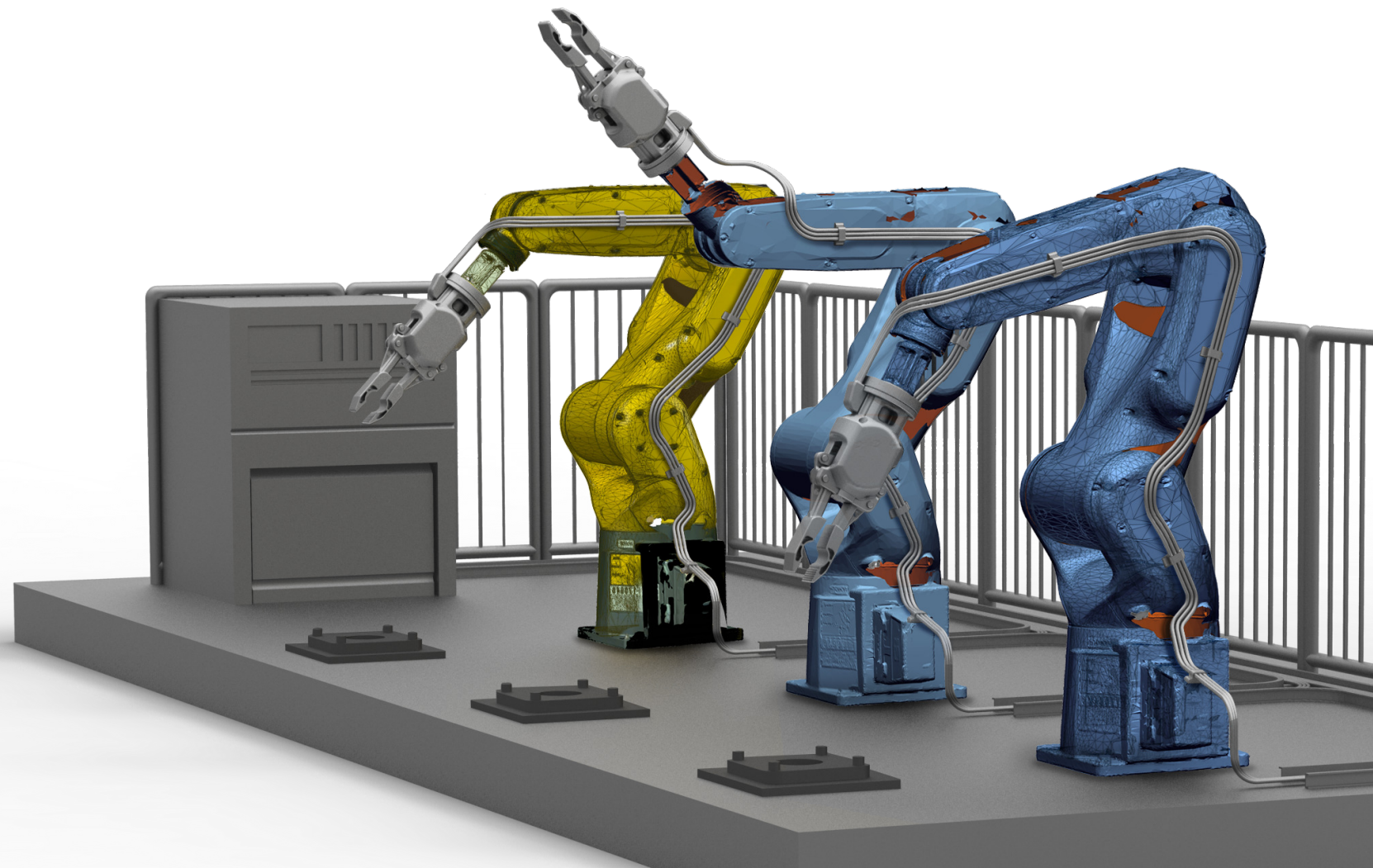

Geomagic for SOLIDWORKS Feature List

Geomagic® for SOLIDWORKS® delivers the seamless ability to 3D scan directly into SOLIDWORKS and use integrated industry proven toolsets to create solid models directly and accurately in your design environment.

Direct Scanner Integration Popular 3D Scanners	Scan or Probe features and sketches directly inside SOLIDWORKS. Supported hardware includes: <ul style="list-style-type: none"> · Creaform Handheld Scanners · Hexagon Scan Arms · Nikon Scan Arms · Artec Handheld Scanners (*via Artec Studio) · Faro Scan Arms and Cobalt Array Imager
Color Scanning and File Import	<ul style="list-style-type: none"> · Directly scan point color information with supported scanners · Import scan data file formats with vertex colors or texture mapping
Point Cloud Processing	Fast, automated processing
Polygonal Surface Creation	Mesh construction from point cloud or merging of multiple meshes
Polygon Processing Tools	<ul style="list-style-type: none"> · Decimation · Noise reduction · Smoothing · Hole filling
Powerful Alignment Tools	<ul style="list-style-type: none"> · Probe device alignment · Align your mesh to the World Coordinate System · Picked point alignment for multiple scan data sets
Automatic Surfacing	Automatic conversion of both organic and geometric objects to CAD solid
Mesh and Point Cloud Cross Sectioning	Automatic curve and sketch creations
Intuitive Smart Selection Tools from Scan Data	<ul style="list-style-type: none"> · Extrude · Freeform surface · Revolve · Primitive feature fitting · Sweep and pipe
Intuitive Smart Selection Tools for Selecting Polygon Groups	<ul style="list-style-type: none"> · Region · Box · Lasso · Polygon · Paint bucket
Region Grouping Tools for Detailed Mesh Segmentation	Pre-processing step for intelligent feature extraction
3D Comparison with Deviation Analysis	Compare any time between mesh and point cloud object and CAD object

Get In Touch

Contact us for a demo at hello@oqton.com